

# The Dating Game: William Walton, the Whiteman Brothers, and the Warren Glass Works

Pete Schulz, Bill Lockhart, Carol Serr, and Bill Lindsey

## History

The history of the Warren Glass Works exemplifies the shifting partnerships, fuel supply problems, and migratory locations so common in the 19th century glass industry. Although the company became an important early producer of milk bottles located in Maryland, its origins lay in the druggists' glassware trade in New York City.

## Walton's Druggists' Glass Works, New York City (ca. 1862-1876)

William N. Walton began advertising his new invention in July 1862, although his patent for recessed panel shelf bottles (see patent section below) was not issued until September. He claimed that his business was the "original and sole manufacturers" of glass labels for druggists' bottles. Walton had previously been employed as a glass cutter at New York's Patent Glass Lettering Co. and operated a crockery and glass store in Newark (Griffenhagen & Bogard 1999:63-64).

By early 1865, Walton was a manufacturer and dealer in "druggists' and other glass ware," located on John Street, advertising the same recessed panel shelf bottles that he had patented in 1862. By May of 1865, he had formed Walton's Druggists' Glass Works with a warehouse on Pearl Street, although "Walton & Harris," still located on John Street, were noted in the same advertisement as "manufacturers of cut glass, glass letters and numerals, for windows and doors." This was presumably the factory, although the wording suggests that the bottles and other glassware themselves – made in green and flint glass and porcelain – were actually made by other factories, with only the glass labels and engraving being made and applied by Walton et al. Besides drug store shelf bottles, the other advertised wares included items such as syringes, graduates, funnels,

patch boxes and perfume bottles. By the end of 1866, Harris had disappeared from the listing and only the Pearl Street address was given (*American Druggists' Circular* 1865a-b; 1866).

By 1875, the company – now located at 39 Warren Street – had changed its name to Walton Glass Works, with Walton & Whiteman as the proprietors (For a summary of all these moves, see Table 1). The name change reflected a change in emphasis, with the engraved and inset labels being especially advertised for bar ware, although druggists' ware was evidently still important. The bottles were reputedly "made at their own factory" (*Crockery Journal* 1875; *Crockery and Glass Journal* 1875).

In mid-1876, the company – noted as W.N. Walton & Co. – advertised that it had "purchased the entire Stock, Business and Good Will" of the Mt. Washington Glass Works in New Bedford, Massachusetts, and had leased their warehouse and sales rooms in Boston (*Crockery and Glass Journal* 1876a). It is likely that this apparent confusion in names represents a situation commonly found in the 19th century, where the factory (Walton Glass Works) went by one name, and the operating company (W.N. Walton & Co.) went by another.

The purpose was evidently a bid for a larger share of the New England market; if so, it had unintended consequences. The timing of Walton's claim corresponds with an 1876 reorganization of the Mt. Washington operation, in which the company name was changed to the Mt. Washington Glass Co. (Wilson 1972:298-299). Since the new company took over the actual factory and all its equipment, the operation was clearly not under Walton's control. It is possible that he hoped to continue as the sales agent for the reorganized New England firm, but it seems likely that the expansion overextended his credit. In October, he was in jail, charged with forging a

Massachusetts check and was unable to raise the \$2,000 bail. This brought to a head dissensions among his partners that had been brewing for several months, and the New York operation was promptly reorganized, sans Walton, as the Warren Glass Works (*Crockery and Glass Journal* 1876b-c).

## Warren Glass Works, New York City (1876-1880)

Reorganized from the fiscal and public-relations ashes of the Walton operation, the Warren Glass Works (named after the company's location on Warren Street) continued advertising bar bottles and druggists' shelf ware. The "patent recess-glass labeled" glassware was manufactured "under license." This was perhaps a deal cut with Erma Walton, but the new company made no bones about the fact that "Wm. N. Walton is not connected with this Establishment." Louis P. Whiteman was noted as the company's "agent," but it seems likely that he was also its guiding light (*Crockery and Glass Journal* 1876d).

The company's ads for the next several years continued the focus on "patent recess labeled glassware" and engraved bar bottles. During most of this period, we have virtually no information on where these containers were produced. At the end of 1878, however, the ads include a notice for the East Stroudsburg Glass Co., Ltd. (Pennsylvania), "Largest Bottle Factory in the United States" and "manufacturers of every variety of green and amber glass and druggists' ware" (*Crockery and Glass Journal* 1878). The purpose for including this notice is unclear. It is possible that East Stroudsburg manufactured all of the Warren operation's wares, the latter firm operating only as a jobber. Alternately, the Stroudsburg factory may have made the bottles while Warren maintained a factory for engraving them and manufacturing inset labels.

An important departure in 1879 was the production of a milk jar with a bail closure for the glass lid, which sealed with a cork ring. This bottle was patented by L.P. Whiteman in early 1880 (Patent No. 225,900). Even before it was submitted to the Patent Office, bottles of this design – “the ultimatum [*sic*] of milk jars” – were being offered by the Warren Glass Works (*Crockery and Glass Journal* 1879). The quick success of the milk jar seems to have inspired the company to establish a new, possibly larger, factory in which all its wares could be produced.

### **Warren Glass Works Co., Cumberland, Maryland (1880-1888)**

Whiteman selected a site in Cumberland, Maryland, where coal was abundant and cheap, glass sand was available, and rail connections provided ready access to eastern markets (Figure 1). Construction on the Warren Glass Works began in late April 1880, and production commenced in September. Although the main product was the milk jars, the plant also made other flint ware including fruit jars, pickle jars, pomade jars, bottles, and lantern globes and chimneys, “as well as heavier goods.” The Walton jars were notably absent. First Louis, then Abram Whiteman, handled sales from the New York office.

The factory was evidently successful from the start. They were advertising private mold work by 1882, and, by 1883, their output reportedly included tableware and glasses. Their cologne bottles were in considerable demand as far west as St. Louis. Initially built with an 8-pot furnace, they added a 12-pot furnace in 1885, doubling their capacity (*Crockery and Glass Journal* 1880a; 1880b; 1881; 1882; 1883a:14; 1883b; 1883c:26; *American Glass Worker* 1885; Cumberland Glass 2007).

By all accounts, the plant’s most important product was the Warren milk bottle. The bottle was widely advertised and touted by editors of farm journals. In the latter notices, we can see the beginnings of the modern milk delivery systems that dominated the milk trade in the following century:

The London Live Stock Journal has the following . . .

Our American friends are shipping milk in glass jars or bottles, not from the producer to the consumer. The idea is an ingenious [*sic*] one, and so far as proving a great success, one farm alone has ordered and has in use over ten thousand of these novel vessels, which, when filled with the milk drawn from the cows, are sealed securely down, with the result that the consumer is insured

[*sic*] of the genuine article, for which the farmer in return can command a paying price. Why should not the experiment be tried in this country?

It will have been observed that bottles expressly made for the above purpose have been advertised in our columns for some time past by the Warren Glass Co. . . . (*Cultivator & Country Gentleman* 1880:761)

For the delivery of milk in cities, etc., glass bottles are rapidly coming into use. The milk is placed in the bottles at the farm . . ., closed with a glass stopper which has a strong spring clamp to hold it tight, and in this form is delivered to the consumer, without chance of any contamination, or of being robbed of its cream while in transit. The Warren Glass Works Co., Cumberland, Md., have given special attention to the making of bottles for this new form of milk delivery, and it is not easy to see how anything can be better suited to the purpose. Milk in such bottles looks so much better, that we are not surprised that the purchaser is willing to pay more for it than for that delivered in the old careless way with can and dipper, in which at each delivery the milk is exposed to the all-pervading street dust which collects upon the ladle, is each time washed off into the can. The bottles are of beautifully clear glass, and present such an attractive appearance that housekeepers, we have no doubt, will be tempted to use them frequently for other purposes than to hold milk (*American Agriculturist* 1881).

In spite of the factory’s success, problems lay ahead. Having doubled the plant’s capacity and its workforce in 1885, the company quickly fell afoul of the Flint Glass Workers Union. In July of that year, the men walked out when the foreman assigned two apprentices to blow bottles. Appeal to the union agreement found the foreman within his rights, and the men agreed to return to work. The company, however, insisted



**Figure 1 – Warren Glass Works, Cumberland, MD (Dale Murschell)**

on discharging two “ringleaders” – whereupon the whole force struck. The dispute lasted at least a year (*New York Times* 1885; *American Glass Worker* 1886b).

In the midst of its labor troubles, the company became entangled in legal disputes with its coal supplier when the quality of the fuel deteriorated with adverse effects on the glass. This resulted in a series of lawsuits and appeals, and the removal of the factory to Uniontown, Pennsylvania, in 1888. The old factory evidently finished out the 1887-1888 fire, but was then closed down. It was leased by the Cumberland Glass Co. in 1889 (*Albany Law Journal* 1886:219-220; *Hagerstown Herald and Torch Light* 1887; *Connellsville Courier* 1889).

**Table 1 – Locations**

Location	Name	Type of Business	Dates
John St.(?), NY	William N. Walton	unknown (jobber?)	ca. 1862-1865
Pearl St.	Walton’s Druggists’ Glass Works	factory	1865-ca. 1875
	Walton & Harris	operating company	1865-1866
	Walton & Whiteman	operating company	1866-1867
39 Warren St.	Walton Glass Works	factory	ca. 1875-1876
39 Warren St.	Warren Glass Works	factory	1876-1880
Cumberland, MD	Warren Glass Works Co.	factory	1880-1888
44 College Pl.	unknown	sales office	1881-1882
72 Murray St.	L.P. Whiteman	sales office	1882?-1885
72 Murray St.	A.V. Whiteman	sales office	1885-ca. 1888
Uniontown, PA	Warren Glass Works Co.	factory	1888-1891

### **Warren Glass Works Co., Uniontown, Pennsylvania (1888-1891)**

Desiring to move their factory to the natural gas belt, and tempted by an offer of cheap natural gas at Uniontown, Pennsylvania, the Whitemans moved their plant there in 1888. It began production in September. The new, 14-pot furnace made “milk bottles and other specialties-all of flint glass.” The “other specialties” included various types of bottles, glasses, and fruit jars (*Crockery and Glass Journal* 1888a-c; *Tyrone Herald* 1888).

The new factory operated in full for the first fire and began the second on the same basis. In November, 1889, however, it was hit with a notice from the gas

company threatening to cut off the fuel supply because “private consumers were the most profitable and . . . they could not spare gas for factories.” Warren and the Thompson Glass Co. – Uniontown’s other glass factory – responded by filing an injunction to force the gas company to fulfill its contracts. The glass works continued to operate as its case moved (unsuccessfully) through the courts. The factory building burned in late 1890, but the molds and equipment were undamaged. The company resumed 11 days later, planning on an even bigger plant (*Crockery and Glass Journal* 1889; *Connellsville Courier* 1890a; 1890b; *Titusville Herald* 1890; *Indiana Gazette* 1890).

Operations continued into early 1891, but the company’s optimism

was misplaced. Enmeshed in the legal conflict over insufficient gas, the company was unable to meet its own orders or pay the contractors working on the expanded facility. By May, 1891, press accounts signaled the demise of the operation:

The contractors have quit work on the new buildings for the Warren works until something definite is arrived at in the gas case and in the financial condition of the works. It is hardly probable that L.P. Whiteman will be able to resume the operation of the works at all, as the absence of gas and the failure to run have necessitated giving up contracts, of

which he had plenty. Besides suits for damages are threatened on all sides by parties with whom he had contracts for work (*Connellsville Courier* 1891a).

The factory was sold at a sheriff’s sale at the end of April, and bought for \$1,113 by E.H. Abraham, the factory superintendent. This failed to satisfy the creditors, and three more sheriff’s auctions followed by the end of 1892. Finally, the Uniontown Glass Works, organized in April 1893, purchased the plant and began operations (*Connellsville Courier* 1891a-b; Roller 1997).

### **A.V. Whiteman, New York, New York (1885-1900)**

From its establishment in 1876 until early 1885, the Warren Glass Works maintained sales offices in New York, with Louis P. Whiteman listed as the company’s agent. This continued even after the Cumberland factory was established in 1880. The only change noted in this period was the moving of the office from 39 Warren Street two blocks west to 72 Murray Street.

From March 1885 onward, the ads were placed by Abram V. Whiteman, still operating at the Murray Street address. Whether for Warren Milk Bottles, Whiteman Fruit Jars or Whiteman Milk Jars, it was brother Abram who ran the New York office under his own name. At some point, Whiteman moved the office from 72 Murray St. to nearby 144 Chambers St. at some point between 1887 and 1889. He continued to advertise until at least 1896, five years after the Warren factory operation (by then in Uniontown) ceased production. Abram received a patent for a jar closure in 1900, the same year that he leased the 144 Chambers St. “store” to James Campbell. Campbell received a five-year lease on the property for \$1,800 (*American Agriculturist* 1885a-b; 1887; *Cultivator and Country Gentleman* 1896; *Ladies Home Journal* 1889; *New York Times* 1900). Despite the evidence of the lease, A.V. Whiteman continued to be listed as a milk jar manufacturer until 1909 – still at the 144 Chambers St.



address. The listing had vanished from the 1912 edition (Thomas Publishing Co. 1905:577; 1907:799; 1909:1101).

Most secondary sources cite A.V. Whiteman as an “executive” or salesperson of the Warren Co. (e.g., Taylor 1971:44; Tutton 1994:4; Giarde 1980:137). However, given that he operated under his own name, with no reference to the Warren company, it seems likely that he purchased his brothers’ shares in the New York operation and carried on independently. It is also clear that he ordered the Whiteman jars from other manufacturers after the Warren factory’s demise (see Containers and Marks section). William E. Whiteman, noted as “a wealthy dealer in milk bottles, whose place of business was at 144 Chambers St.,” died under somewhat mysterious circumstances in early August 1901 (*New York Times* 1901). Although William was rarely mentioned in other sources, this reference *may* indicate that the office was still open in 1901.

### Walton Patents

William N. Walton based most of his business on his only patent (and a reissue).

### September 23, 1862 – Improvement in Attaching Labels to Bottles

William N. Walton received Patent No. 36,542 on September 23, 1862, for an “Improvement in Attaching Labels to Bottles.” In Walton’s patent, the bottle was molded with a recessed section on the upper center of the body. A label was then glued into the recess, and an identically shaped piece of glass was glued in atop the label. This kept the label from being obliterated, defaced, or loosened when acid or other corrosive substances contained in the bottle were spilled. Druggists were Walton’s target market. As noted by Griffenhagen and Bogard (1999:64), Walton’s patent was for the outside glass label. Since Walton began advertising the new method in July of 1862, it is very likely that he had applied for the patent by that time. Prior to ca. 1878, patent documents did not include the date of application.

### May 28, 1867 – Improvement for Attaching Labels to Bottles

Griffenhagen and Bogard (1999:65) noted that the original patent “was defective in both the specification and the drawings,” which resulted in the reissue. They further noted that the reissue was for two separate patents, one for the label and one for the bottle. The first reissue (No. 2,360), dated May 28, 1867, was for an “Improvement for Attaching Labels to Bottles” (Figures 2-4). Essentially, the description removed the information about the label from the original patent, added additional description, and pasted it all into the reissued patent document. This separated the labeling process from the bottle design.

### May 28, 1867 – Improved Bottle for Druggists and Chemists

The second reissue document (No. 2,631), also dated May 28, 1867, was for an “Improved Bottle for Druggists and Chemists.” A perplexing aspect of the reissues is that both documents were in the name of “Elma E. Walton, of Newark, New Jersey, Assignee by Mesne Assignments of William N. Walton.” The name “W.N. Walton” also appears at the top of the second reissue document, although “E.E. Walton” is atop the initial one. “Mesne” means intermediate or intervening and is often used as a legal term, indicating the

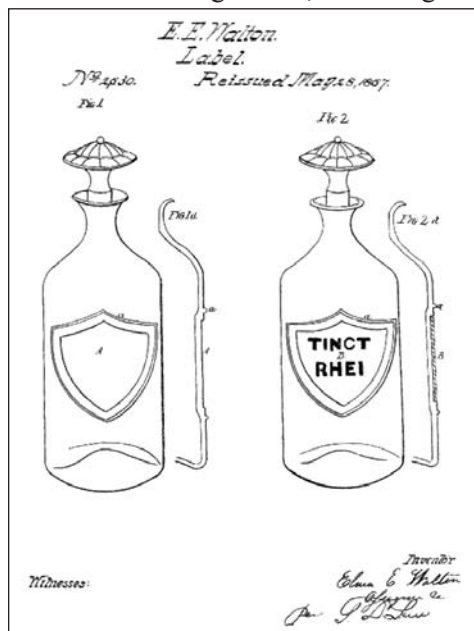

Figure 2 – Walton’s 1867 reissue patent for a label-under-glass bottle (U.S. Patent Office)



Figure 3 – Walton label-under-glass bottle (Dale Murschell)



Figure 5 – Label-under-glass side view (eBay)

assignment of profits to an intervening party. Erma Walton was presumably William’s wife. We have been unable to determine the reason for the assignment of the patents to Elma Walton.

### Whiteman Patents

Both Louis and Abram Whiteman obtained patents for jars and closures. In addition, George L. Carll and Benjamin F. Sanborn patented lids in the same sequence of inventions and assigned them to Abram Whiteman. For a summary of Whiteman patents and closures, see Table 2.

### April 2, 1878 – Improvement in Jars for Preserves and Fruit

On February 22, 1878, Louis P. Whiteman applied for a patent for and “Improvement in Jars for Preserves and Fruit” and was granted Patent No. 201,969 on April 2, 1878. He described his closure as “an externally screw-threaded, plate-like cover” made of glass. Caniff (2001:34) came across the only example we have found for the use of this patent. He described a jar, sealed by a

milk glass lid, with highly-raised bumps around the top, . . . lettered within this area in red, THE CRAIG BAKING POWDER CO. CLEVELAND, O., all within a circle. It appears that the lettering was stamped on the lid, which was probably then refired to set the “ink,” melted glass, or whatever they used in this case.

Of more pertinent issue to this study, Caniff noted that “the glass lid is actually screwed into the nickel-plated-steel screw band. There is a thin spiral thread around the outer edge of the lid that locks into the threads on the band.” In his search, the only patent Caniff could find that matched this description was the one issued to Louis Whiteman in 1878 (Figure 5).

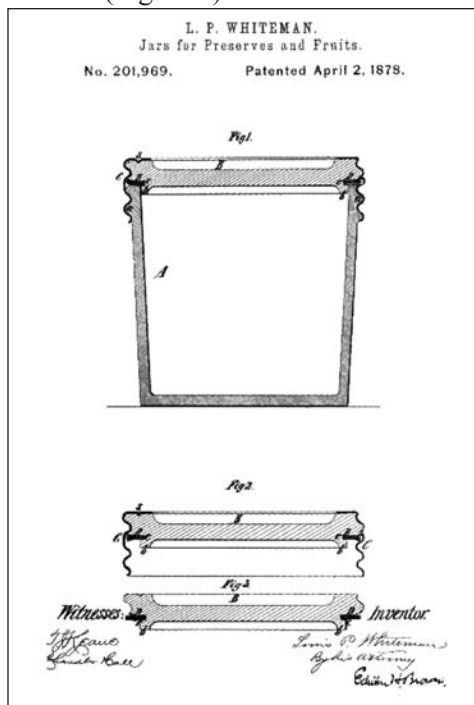

Figure 5 – L.P. Whiteman’s 1878 product jar patent (U.S. Patent Office)

Dr. William Craig began manufacturing “Craig’s Baking Powder and Flavoring Extracts” prior to the fall of 1870, when he sold the business and moved to California. What he actually called the firm is currently unknown to us. The Craig Baking Powder Co. was in business under that name at Cleveland, Ohio, by at least July 26, 1884, as attested by an entry from the Ohio General Assembly. A billhead indicates that the company remained in business until at least July 13, 1900 (Brown 2008; General Assembly of the State of Ohio 1885:1086; Redlands Daily Facts 1897).

It is thus clear that Craig was in business at an opportune time to have used the Whiteman lid. This suggests that the closure was actually manufactured, albeit without stamped or embossed patent data. Generic jars using the lid were likely first made at the New York plant, and their production may have continued at Cumberland.

### March 23, 1880 – Jar for Milk &c.

Louis Whiteman applied for a patent on January 31, 1880, for a “Jar for Milk &c.” and received Patent No. 225,900 on March 23 of that year (Figure 6). Although the patent was for the jar, it centered around the cap, made of “metal

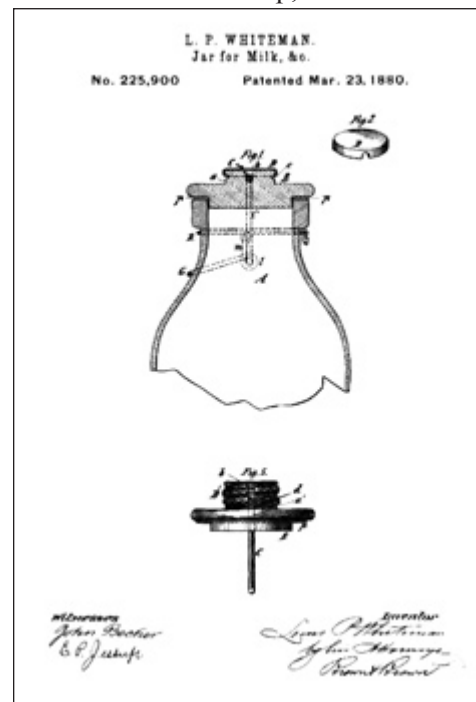

Figure 6 – L.P. Whiteman’s 1880 milk jar patent (U.S. Patent Office)

or other suitable material” and held in place by a wire-bale arrangement. The seal was affected by a “flange overlapping the mouth of the jar, sealing it with the aid of a packing ring . . . preferably of cork.” Known as the Warren Milk Bottle, the bottle was advertised at least as early as July 1879 (Figure 7), before the patent was awarded or the application even filed (*Crockery & Glass Journal* 1879; Tutton 1994:4).

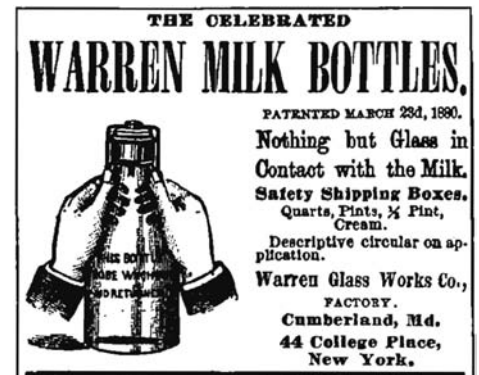

Figure 7 – Warren Milk Bottle ad (*Crockery & Glass Journal* 1879:16)

Taylor (1971:39) published good photos of the bottle and base. Since the bottle was marketed before the Warren Glass Works actually built its own plant, the earliest of these bottles must have been made for them by another factory. Apparently, the rapid success of this patent inspired the creation of the company’s glass factory in Cumberland.



Figure 8 – Warren Milk Bottle (Doug & Linda 2005-2009)



The website sponsored by Doug & Linda (2005-2009) included a photo of a “Warren Milk Jar” (Figure 8) and noted that

the underside of the glass lid is embossed with a patent date of Jan. 5, 1875, revised June 5, 1877. This patent and revision was issued to Charles DeQuillfeldt of New York, New York[,] for an improvement in bottle stoppers. This was the original patent for the Lightning style bottle closures found on many beer bottles.

The lid was “loose when the bail is tightened to allow for a packing ring to seal the bottle and cushion the glass on glass. We have seen references to the packing material being rubber or cork.” The actual bottle was “patented by Louis P. Whiteman of New York, New York[,] on March 23, 1880.” The researchers speculated that the bottle “was made before the patent was granted since it references the DeQuillfeldt patent rather than the Whiteman patent” and noted that they had “seen advertisements for this milk bottle that date from August of 1879, before the patent was granted.” The base of the bottle was embossed “WHITEMAN.”

Giarde (1980:133) also noted a cover from a Warren milk bottle with “several patent dates from the 1870’s . . . with the Warren milk bottle patent date of March 23, 1880[,] also on the lid.” Thus, lids contained at least two embossed patent formats: one with the 1880 patent date, the other with only the 1875 and 1877 patent dates.

#### April 3, 1883 – Stopper or Cover for Bottles or Jars

On October 1, 1882, Abram V. Whiteman applied for a patent for a “Stopper or Cover for Bottles or Jars.” He received Patent No. 275,101 on April 3, 1883. This was Abram’s first patent. Unlike both patents obtained by brother Louis, this closure was made from “two pieces or thicknesses of sheet metal fitting snugly together and having their edges overlapped, one provided with a

downwardly-extending annular rim or projection adapted to fit within the mouth of the bottle or jar,” although the lid was still held in place by a wire swing bail (Figure 9). This cover was flat and was probably superseded by the September 4 lid.

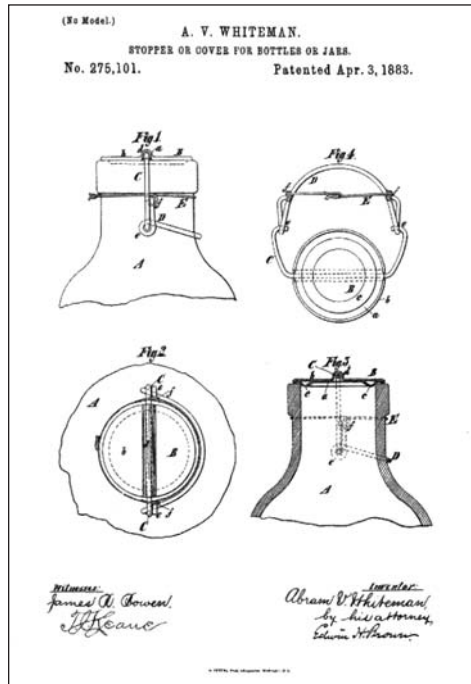

Figure 9 – A.V. Whiteman’s first 1883 patent (U.S. Patent Office)

Doug & Linda (2005-2009) showed a photograph of a Cream Line milk bottle (Whiteman 1890 patent) with an “enameled tin bail top” that they identified as the one patented by Whiteman on April 3, 1883. The bottle base had the 144 Chambers St. address. An example from Paul Doucette confirms a lack of embossing on a lid that appears to be from the April 3, 1883 patent and is also affixed to a Cream Line milk bottle (Figure 10). It seems strange that the



Figure 10 – Tin-top bail lid with no patent information (Paul Doucette)



Figure 11 – Bottle used from 1883 to at least the 1890s (Dale Murschell)

older lid was still used on a bottle that is at least seven years newer – despite at least three patent changes in between. It may be that the other lids did not prove to be as effective. This actual bottle style was used from 1883 until at least the 1890s (Figure 11).

#### September 4, 1883 – Stopper for Bottles and Jars

Abram applied for another patent for a “Stopper for Bottles and Jars” on May 31, 1883, and received Patent No. 284,523 on September 4, 1883. Although this was another wire swing bail stopper, it differed in two major ways from the one Whiteman had patented earlier in the year: 1) the metal stopper was conical, instead of flat; and 2) the bail was anchored in two debossed “holes” in the bottle’s neck/shoulder joint, instead of being held in place by a wire arrangement (Figure 12).

#### September 23, 1884 – Jar

Giarde (137-138) and Taylor (1971:44-45) both discussed a patent for milk jars or fruit jars advertised by Whiteman in the late 1880s. Tutton (1994:6) illustrated the patent, No. 305,554, issued to A.V. Whiteman for a “Jar.” Whiteman applied for the patent on June 18, 1884, and received it on September 23 of that year. He stated that

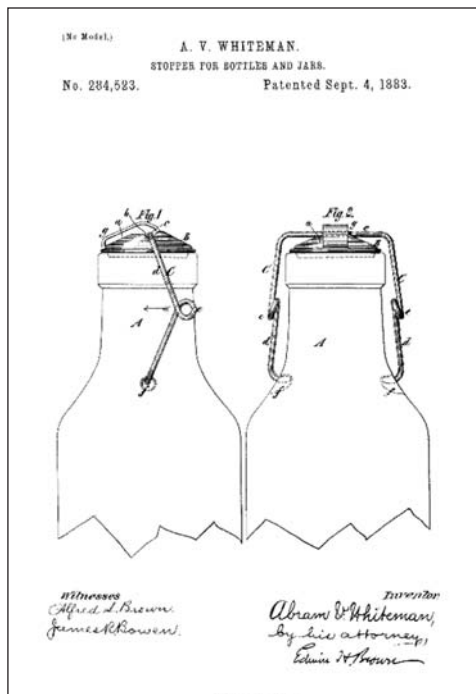

Figure 12 – A.V. Whiteman’s second 1883 patent (U.S. Patent Office)

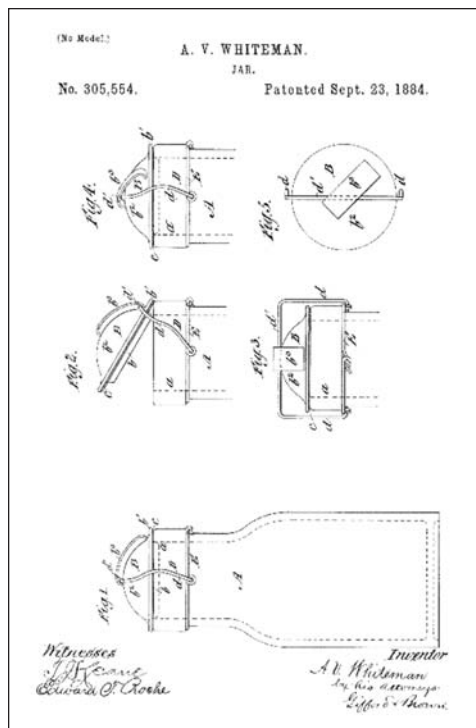

Figure 13 – A.V. Whiteman’s 1884 patent (U.S. Patent Office)

his objective was “to provide a jar with a cover connected thereto by simple means” (Figure 13) This improved on his 1883 patent.

Giarde (1981:137-138) speculated on the possibility that the milk jar Whiteman advertised as an 1884 patent was actually a fruit jar, as claimed by fruit jar collectors. He further noted that Whiteman’s 1885 ads mentioned the Warren milk bottles

and Whiteman fruit jars, but no Whiteman milk jar. The actual patent, however, stated that it was for a “useful Improvement for Jars for Containing Milk and other Liquids and Substances” (Creswick 1987:247; Roller 1983:408).

This created some confusion. A.V. Whiteman *did* advertise the Whiteman Fruit Jar – illustrated and with the 1884 patent date (*Crockery and Glass Journal* 1885). Roller (1983:330) illustrated the ad and noted that it included the September 23, 1884, patent date – but actually showed the lid from the 1885 patent. The fruit jar illustration was embossed on the face: “THE WHITEMAN (arch) / PAT. SEPT. 23 - 84 (horizontal) / FRUIT JAR (inverted arch)” (*Crockery and Glass Journal* 1885). Unfortunately, this seems to have been created for the ad; none of the fruit jar sources described such an embossing.

Meanwhile, Whiteman continued to advertise the old Warren Milk Bottle (with the 1880 patent date) until at least February 1887 (*American Agriculturist* 1887). The first ads we have discovered for the newer Whiteman Milk Jar are from 1889 (*Ladies Home Journal* 1889). However, the milk bottles and fruit jars are not the same. The fruit jars shown in his ads are of typical fruit jar shape with very short necks, while the milk jars have much longer and more sloping necks (probably identical to the old Warren Milk Bottle). The finish and closure on these Whiteman fruit jars and milk jars, however, are identical: a wide band finish and a domed closure as shown in the 1884 patent illustration. Thus, the container was not used alternatively for fruit and milk as indicated above – the two jar types were quite distinct. Only the sealing form was identical.

Doug & Linda (2005-2009) included a photo of a milk bottle with this lid. The illustrated bottle is generic but has the more gently sloped shoulders typical of later milk bottles (unlike the abrupt slope of the Warren Milk Bottle (see Figure 8). They noted that the patent date on the cap was Sept. 23, 1884. It is thus apparent that the lid was available for both milk and fruit jars – although its use on fruit jars has not been demonstrated.

## June 16, 1885 – Fruit Jar

The Warren Glass Works Co. website (Cumberland Glass 2007) claimed a patent date of June 16, 1885, for a fruit jar. The anonymous author stated that he had not been able to find any of the Warren jars, and we have been equally unable to find any references in the usual fruit jar literature. Whiteman, however, filed for a patent on January 27, 1885, and received Patent No. 320,107 for a “Fruit Jar” on June 16, 1885 (Figure 14). The main point of this invention was a cover that was “entirely unconnected with the jars” – a “desirable” improvement in his opinion. The metal closure was bell or dome shaped and was held in place by a wire bale arrangement roughly similar to the one patented in 1884 but with the closure unconnected to the wire.

Roller (1983:330) illustrated two ads, both of which featured virtually identical drawings – that are both very close to the patent illustration. One, predictably, called the jar the “Whiteman Fruit Jar” and listed A.V. Whiteman at the 72 Murray St. address in 1885. Although this ad illustrated the lid patented in 1885, it claimed the 1884 patent! The other ad, however, was from a ca. 1887 A.G. Smalley & Co. catalog and showed a jar with the “SEP. 23 ‘85” patent date on the front. It is thus apparent that either the Whitemans made these jars for Smalley,

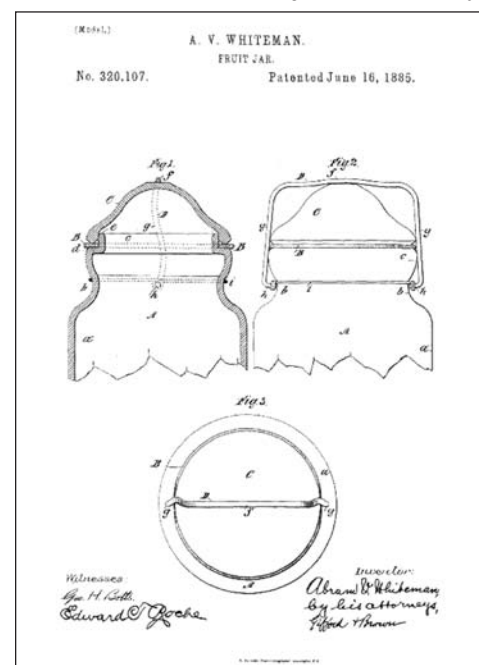

Figure 14 – A.V. Whiteman’s 1884 patent (U.S. Patent Office)



or they allowed Smalley to use the patent. Creswick (1987:195) illustrated the jar, embossed “THE / SMALLEY / JAR (all horizontal)” and noted both Whiteman patent dates (although neither was embossed on either the jar or the lid). Leybourne (2001:349) also noted a half-gallon variation with “THE SMALLEY JAR (in circle)” *debossed* on the front (Figure 15).



Figure 15 – Smalley Jar, made from Whiteman’s 1885 patent (Leybourne 2001:349)

Roller (1983:279) also presented another A.V. Whiteman fruit jar ad, this one from August 1886. The ad illustrated a jar embossed “THE WHITEMAN (arch) / PAT JUNE 16 85 (horizontal) / PRESERVE JAR (inverted arch).” Actual jars, however, were only embossed “PATENTED / JUNE 16 1885” with the same embossing on the lid. Oddly, the lid in the drawing (and



Figure 15 – Another fruit jar made from the Whiteman 1885 patent (Creswick 1987:171)

on the actual jar) was not as close to the shape of the patent drawing as the one illustrated in the 1885 ad (with the 1884 patent date). Creswick (1987:171) illustrated the jar and agreed with the patent assignment (Figure 16). She noted that the jar was only reported in a half-pint size.

**April 17, 1888 – Jar [Whiteman Milk Jar]**

By at least January 1891, Whiteman was advertising his milk jars, patented on April 17, 1888, and stressed that “dipping milk out of cans peddled about the street, subject to dust and rain and drip from the reins and hands of the driver, is unhealthy and dirty” (Giarde 1980:137; *Ladies Home Journal* 1891 – Figure 17). This almost certainly



Figure 17 – Ad for G.L. Carl’s 1888 patent milk jar

referred to the George L. Carl Patent No. 381,331. Carl filed on this patent for a “Jar” on October 21, 1887, and received it on April 17 of the following year. He assigned the patent to Abraham [sic] V. Whiteman. Carl noted that his “improvement relat[ed] more specifically to jars containing milk” (Figure 18).

Even though this patent claims to be for the bottle (or jar), it is really more about the closure. This patent had the “desirable” improvement of the wire bale arrangement like the 1885 Whiteman patent, but it returned to a flat lid. This flat lid is a defining feature on the closures used after at least 1890. Doug & Linda (2005-2009) noted that they had “never seen this bottle cover even though it was advertised by A.V. Whiteman.”

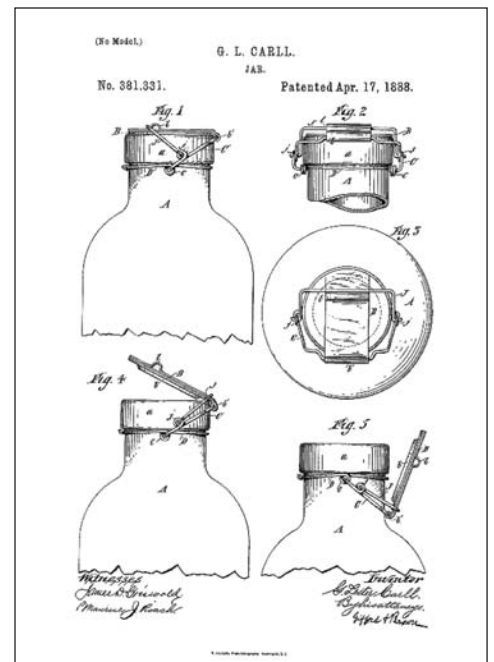

Figure 18 – G.L. Carl’s 1888 milk jar patent (U.S. Patent Office)

**February 18, 1890 – Milk-Jar**

Abram Whiteman filed for another patent on October 31, 1888, for a “Milk-Jar” and received Patent No. 421,461 on February 18, 1890. The jar, itself, “may be of any desirable shape” with a cover made from metal “or any suitable material.” What made the container unique was “three marks or lines extending around the neck portion of the jar . . .



Figure 19 – Whiteman’s 1890 patent for the Creamline milk bottle (U.S. Patent Office)



formed by blowing them into the jar [i.e., embossed].” The lines were designed to show the customer the quality of the milk as determined by the percentage of cream it contained (Figure 19). The closure actually drawn in the patent document was the one Whiteman patented in 1884. Tutton (1994:19) noted that these bottles are found with “tin tops, dome caps and with the common sense cap seat” in pint and quart sizes. Taylor (1971:47) provided good photos of the bottles.

Whiteman advertised the “Whiteman’s Standard Indicating Milk Jars” at least as early as February 1896, although these are better known as “Standard Cream Line” or just “Cream Line” bottles by collectors. These had a line just below the neck-shoulder junction embossed “5%” and another line farther down the shoulder embossed “12 ½% STANDARD CREAM LINE” (Figures 20 & 21) According to the patent drawing, the jar was sealed with a Lightning-style fastener, probably identical to that in Carll’s 1888 patent. The company also offered “plain jars and sundries” (*Cultivator & Country Gentleman* 1896). This was the only major patent after the initial milk jar in 1880 that indicated a significant change in the *bottle* rather than the fastener.



Figure 20 & 21 – Creamline milk bottle (eBay) - (inset) Shoulder and finish of the Creamline milk bottle (eBay)

### October 25, 1892 – Bottle-Stopper

Benjamin F. Sanborn, Flatlands, New York, applied for a patent for a “Bottle-Stopper” on December 30, 1891, and was awarded Patent No. 485,139 on October 25, 1892. He assigned the patent to Abram V. Whiteman. The stopper was a flat-top metal design held in place by a wire bail (Figure 22 & 23). The Sanborn patent is basically a slight modification of the 1888 Carll patent. Doug & Linda (2005-2009) described a lid stamped with this patent date on one of the Cream Line bottles, and an eBay auction illustrated the lid on a bottle embossed “POWELL & LOCKWOOD” on the base (see below).

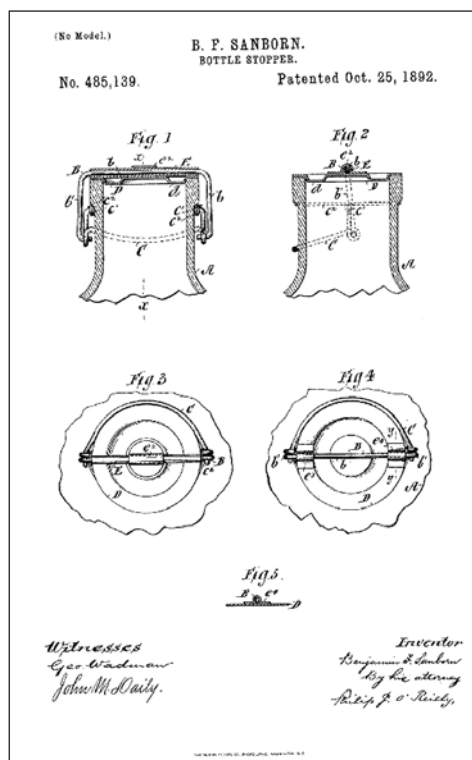

Figure 22 – Benjamin F. Sanborn’s 1892 milk jar patent (U.S. Patent Office)



Figure 23 – Sanborn’s 1892-patent lid (eBay)

### December 18, 1900 – Bottle-Cap

On June 8, 1899, Abram V. Whiteman applied for another patent, this time, a “Bottle-Cap.” He was awarded Patent No. 663,988 on December 18, 1900. The invention contained “improvements in caps for milk-bottles and the like” and consisted of yet another metal closure held in place by a wire bail (Figure 24). This was an adaptation of the 1892

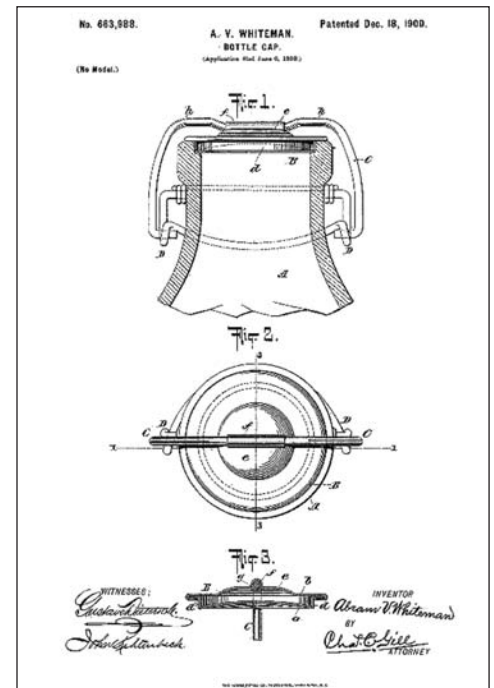

Figure 24 – Whiteman’s 1890 patent (U.S. Patent Office)

closure that would fit into the cap-seat finish of the Common-Sense milk bottle. The design was Whiteman’s last patent.

### Containers and Marks

Walton, Warren Glass Works, and Whiteman used a variety of containers with a great deal of variation in closures. In addition, there was a great deal of variation in the manufacturer’s marks. See Table 3 for the Walton marks and containers and Table 5 for the marks used by Whiteman and the related containers, closures, and chronology.

### Walton Jars

#### W.N. WALTON (1862-1879)

Griffenhagen and Bogard (1999:65) noted that jars with the Walton patent recessed glass labels were embossed “W.N. WALTON PAT<sup>D</sup> SEPT 23<sup>D</sup>, 1862”

**Table 2 – Whiteman and Whiteman-Related Closures/Containers**

Patent Date & Number	Defining Characteristics	Container Type	Ads	Actual Use
April 2, 1878 (201,969)	screw cap threads on both glass insert and finish	product jar		Craig Baking Powder (Caniff 2001:34)
Jan. 5, 1875 (158,406) June 5, 1877 (7,722)	“Lightning” tin top with wire bales	Warren Milk Bottle	July 1879	(Doug & Linda 2005-2009; Giarde 1980:133)
Mar 23, 1880 (225,900)	glass insert with wire bale	Warren Milk Bottle	1880-Feb 1887	(Doug & Linda 2005)
April 3, 1883 (275,101)	2-piece tin lid with bale wire cover completely across top of lid	Warren Milk Bottle, generic milk bottle, Cream Line milk bottle		(Doug & Linda 2005)
Sep. 4, 1883 (284,523)	conical lid; flat restraining strap; wire bale anchored in holes below finish	milk bottle – may never have been used		
Sep. 23, 1884 (305,554)	similar to Sep. 4, 1883, but wire bale anchored in wire below finish	jar or generic milk bottle	1884 (patent date)	(Doug & Linda 2005) [patent date on milk bottle lid]
June 16, 1885 (320,107)	bell-shaped lid; wire bale <i>not</i> connected to lid	fruit jar; The Smalley Jar	1885 (illustration); 1886 (pat. date & ill.)	(Creswick 1987:171, 195; Roller 1983:279, 330)
Apr. 17, 1888 (381,331) George L. Carll	wire bale pushed over a raised “bump” to raise lid	Whiteman Milk Jar? – probably never used	1888?	
Feb. 18, 1890 (421,461)	embossed “cream lines” at shoulder and neck	Cream Line milk bottle (Whiteman Milk Jar?)	1890-1896	(Taylor 1971:47; Tutton 1994:19)
Oct. 25, 1892 (485,139) Benjamin F. Sanborn	indented circle in flat lid; wire bale only partly covered where it attached to lid	Cream Line milk bottle, generic milk bottle		(Doug & Linda 2005)
Dec. 18, 1900 (663,988)	made to fit into cap-seat finish	unknown – may never have been used		

in a circle on a Rickett’s style base mold around a concave center post bottom (Figure 25). This marking, however, was only used between 1862 and 1867. Jars made after May 28, 1867, had the reissue patent date.

According to Griffenhagen and Bogard (1999:65), jars with the Walton recessed glass labels added the reissue patent information from 1867 to 1879.



**Figure 25 – Jar base, W.N. Walton, September 23, 1862 (eBay)**

This implies that the bottles were made by (or for) Walton’s plant in New York City between 1867 and 1876 and by the Warren Glass Works (same location from 1876 to 1880), when the Warren company built its plant at Cumberland, Maryland. These jars had “W.N. WALTON (arch) / PATD SEP<sup>T</sup> 28<sup>TH</sup> 1862 (inverted arch)” embossed in a Rickett’s type plate around the outside edge of their bases with “2 REISSUES (arch) / MAY 28<sup>TH</sup> 1867 (inverted arch)” embossed on the concave post

mold in the center of the bases (personal communication from Frank Sternad, 10/27/2009). Note that the September 28 date on these bases is incorrect; the original patent was issued on September 23 (Figure 26). Also see below for a Warren mark on these jars.

### Whiteman Bottles

As mentioned above, the Warren Glass Works almost certainly continued to produce the “label under glass” druggists’ bottles at the New York factory

**Table 3 – Walton Patent Sunken Label Jars**

Outer Ring Embossing	Inner Ring Embossing	Factory	Dates
W.N. WALTON PAT <sup>D</sup> SEPT 23 <sup>D</sup> , 1862	none	Walton’s Druggists’ Glass Works, NY	1862-1867
W.N. WALTON / PATD SEP <sup>T</sup> 28 <sup>TH</sup> 1862	2 REISSUES / MAY 28 <sup>TH</sup> 1867	Walton’s Druggists’ Glass Works, NY	1867-1876
W.N. WALTON / PATD SEP <sup>T</sup> 28 <sup>TH</sup> 1862	2 REISSUES / MAY 28 <sup>TH</sup> 1867	Warren Glass Works, NY	1876-1880
WARREN GLASS WORKS NEW YORK & CUMBERLAND M <sup>D</sup>	none	Warren Glass Works, Cumberland, MD	ca. 1880





**Figure 26 – Jar base, W.N. Walton, September 28, 1862 – error date (Frank Sternad)**

during the 1876-1880 years, still using the Walton patent and base logo. The manufacture of those bottles probably continued for the first few years at the Cumberland location. Dale Murschell contributed a photo of one of these bottles embossed “WARREN GLASS WORKS NEW YORK & CUMBERLAND NY” in a circle on a Rickett’s-style plate on the base (Figure 27).



**Figure 27 – Jar base, Warren Glass Works (Dale Murschell)**

Milk bottles were made by or for the Whiteman brothers in at least three shapes – each defined by the configuration of the shoulders. The oldest, the Warren milk bottle, had a very sharp, abrupt shoulder (see Figure 8). Some (possibly all) of these were embossed “THIS BOTTLE / TO BE WASHED / AND RETURNED” on the reverse. An intermediate shape had a more rounded, gradual shoulder (see figure 10). Some of these were embossed “THIS BOTTLE / TO BE WASHED / AND RETURNED / NOT TO BE

BOUGHT OR SOLD” on the reverse, but others were generic. The final Cream Line bottles had gentle, slightly rounded slope to the shoulder (see Figure 20). Some of these were embossed with the “washed” plus “bought or sold” directive; others had no embossing on the reverse. An unusual reverse embossing was brought to our attention by Paul Doucette (personal communication, 11/15/2009). His bottle is embossed “THIS BOTTLE / TO BE RETURNED.”

In addition, the finish shapes varied slightly. All of the patent drawings, except the final one (1900), showed squared finishes (when viewed from the side). The final one was more rounded. Actual bottles have both squared and rounded finishes. Squared finishes are attached to Warren milk bottles, but both the intermediate and Creamline shapes were made with both round and squared finish designs. Although we have not been able to examine a bottle closely, the rounded shape may indicate a Common Sense finish (i.e., one with the cap-seat ledge inside the throat of the bottle). See Table 4 for a summary of Creamline variations.

The final major variation was in closures (see the Patent section above). Thus, the most accurate dating may be achieved by a combination of bottle shape, closure style (and/or patent information on the finishes), and basal embossing.

### WHITEMAN

According to Doug & Linda (2005-2009), a Warren milk jar was embossed “WHITEMAN” on the base and “THIS BOTTLE / TO BE WASHED / AND RETURNED” on the reverse. The bottle had a circular plate mold on the front but no embossing. One of these was offered on eBay. It, too, was only embossed “WHITEMAN” on the base



**Figure 28 – Whiteman milk jar base – WHITEMAN (eBay)**

with the same “WASH” warning on the reverse (Figure 28). The front plate was embossed “ABBOT & SONS (arch) / HILSIDE-DAIRY (inverted arch).”

### WHITEMAN (Murray St – 1879-ca. 1888; Chambers St. – at least 1889-ca. 1896)

As the selling agent for the Warren Glass Co., Louis Whiteman marketed the Warren milk bottles embossed on the base with “WHITEMAN (arch) / 72 MURRAY<sup>ST</sup> (horizontal with two dots below the underline) / NEW YORK (inverted arch)” (Taylor 1972:39; Tutton 1994:4). The bottle was advertised at least as early as July 1879. A slight variation was similarly marked, although the word “MAKER” (also horizontal) was inserted above the Murray St. address on the base (Taylor 1971:45 – Figure 29). It is interesting to note that the embossing around the edges of the base actually became the resting point for the bottles. In other words, the embossing is what actually made contact with the surface upon which the bottle rested.

It is worth noting that a contemporary reference to this embossing arose during the company’s labor troubles. In January 1886, a labor journal, noting the prolonged strike of the Flint Glass Workers Union noted – with an eye toward a potential boycott – that

**Table 4 – Cream Line Variations**

Type	Line 1*	Line 2	Line 3	Below Line 2
1	5% (f)	12½% (f); STANDARD CREAM LINE (r)	none	WHITEMAN’S PATENT (f) FEB. 18 1890 (r)
2	none	12½% (f); STANDARD CREAM LINE (r)	none	WHITEMAN’S PATENT (f) FEB. 18 1890 (r)
3	5% (f)	12½% (f); STANDARD CREAM LINE (r)	15%	unknown

\* Embossing is above the lines.



Figure 29 – Whiteman milk jar base, 72 Murray St. address (Dale Murschell)

The firm mainly makes milk bottles, which have the name “Whiteman” blown into the bottles. The “scab” bottles are sold mainly in New York . . . Will union men please take notice, and set the ball rolling (*American Glass Worker* 1886a)

A generic bottle (The Whiteman Milk Jar?) was possibly made earlier than the final variation, a Cream Line bottle that was patented on February 18, 1890. The final bottle had a cream line just above the shoulder and another at the neck/shoulder junction. The patent date was embossed just below the shoulder cream line with “12 ½ %” just above the line. The upper line was embossed “5%.” On some bottles, a third line was labeled “15%.”

Bases of both bottle styles had at least four variations (see Table 5), the most common of which was “WHITEMAN (arch) / M / 144 CHAMBERS ST. / 4 (all horizontal) / N. Y. (inverted arch)” (Figure 30) – although the “4” could be replaced by 1, 2, or 3 (Taylor x1971:47; Doug & Linda 2005-2009). At least some of the Cream Line milk bottles were made for Whiteman by the Thatcher Mfg. Co.

Another auction showed a photo of a bottle with the 5% and 12 ½% lines with a base embossed “A.V. WHITEMAN (arch) / T.MFG.CO. (horizontal) / 144 CHAMBERS ST. N.Y. (inverted arch).” Part of the manufacturer’s mark was obliterated by an Owens scar (Figure 31). The central logo was used by the Thatcher Mfg. Co. from 1905 to 1926.



Figure 30 – Whiteman milk jar base, 144 Chambers St. address (eBay)



Figure 31 – Whiteman milk jar base, made by Thatcher Mfg. Co. (eBay)

#### POWELL & LOCKWOOD

Two eBay auctions featured Whiteman milk bottles with bases embossed “POWELL & LOCKWOOD (arch) / MAKERS / 112 CHAMBERS ST. (both horizontal) / NEW YORK (inverted arch).” One was a generic bottle, but the other was embossed “PROPERTY OF / LAWNFIELD FARM (both arch) / HENNIKER, N.H. (inverted arch)” on the front (Figure 32). The firm of Powell & Lockwood was listed in 1890 as dealing in “Farming Tools” at 112 Chambers St., a five-story brick building. They were obviously jobbers – not manufacturers – despite the “MAKERS” designation on the bottles (New York Board 1891:118).

The lid (shown in Figure 23) in the Powell & Lockwood eBay photos was from the 1892 Sanborn patent. The base of the bottle appears to have been altered from the earlier “72 Murray St.” variation. Compare Figure 29 with



Figure 32 – Whiteman milk jar base, made by Powell & Lockwood (eBay)

Figure 32, and note that this bottle, too, used the embossing as a resting point. The “S” in “MAKERS” on the Powell & Lockwood bases has certainly been added in both eBay photos, and the “2” in “112” is out of alignment with the “11” in one of them. Each Powell & Lockwood base is from a different mold. The lettering is just different enough to show, even on eBay photos, that the glass house that made bottles for Powell & Lockwood used at least two molds.

#### Warren Glass Works Jars

##### WARREN GLASS WORKS Co. (1880-1888)

Warren Glass made at least two jars embossed with the company name. One, a small jelly jar with a continuous-thread finish, was embossed “WARREN GLASS WORKS CO. CUMBERLAND MD.” in a plate mold on the front (Cumberland Glass 2009). The exact configuration is currently unknown.

Another tin-top jelly jar was embossed “WARREN GLASS WORKS CO. 72 MURRY St.” on the front (Cumberland Glass 2007). Neither of these appears in any of the Fruit Jar sources.

Caniff (2008:6-7) noted another jar that was embossed “WARREN GLASSWORKS CO. MAKERS NEW YORK AND CUMBERLAND. MD” on the base. Caniff described the closure as a “metal screw cap has a rounded wire bail, the ends of which are fitted into metal loops soldered to the top of the cap” (Figure 33).



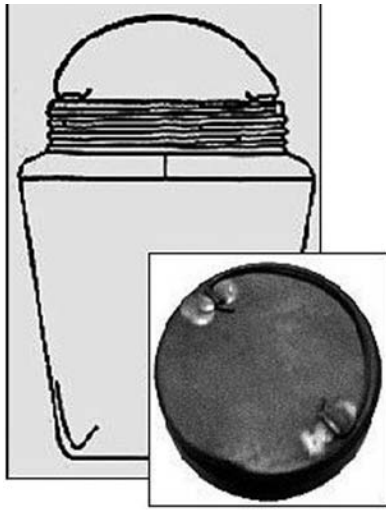

Figure 33 – Warren Glassworks Co. product jar (Caniff 2008:6-7)

### Discussion and Conclusions

William Walton was a mysterious character who left us with unanswered questions. Why did he reassign the druggists' jar patents to his wife (assuming that Elma *was* his wife)? Was he already skirting legal trouble in 1867? Were the name changes for the company (companies?) in the late 1870s all to dodge legal issues? We may never know.

Patent dates on the Walton recessed-glass-label jars makes dating the early jars easy (see the Walton Jar section above), but the later jars may be a bit more problematical. The Whitmans continue to make the jars, at least for a brief period, after the Cumberland

factory opened in 1880. These were marked with the Warren Glass Works name, along with the New York (probably sales office) and Cumberland (certainly factory) designations. It is possible that an intermediate jar was marked only with Warren Glass Works and New York.

Initially, Louis appeared to be the guiding light behind the Whiteman brothers' efforts. He signed the initial two patents, although all later patents appeared under Abram's name. Similarly, Louis was the first agent, with Abram moving into that position by 1885. The 1885 appearance of A.V. in the ads, with no reference to the Warren Glass Works, may signal a splitting of the company,

Table 5 – Warren/Whitman Milk Bottle Basemarks

Basemark	Reverse Embossing	Bottle Types	Closures	Dates
WHITEMAN	THIS BOTTLE TO BE WASHED AND RETURNED	Warren Milk Bottle	Pat 1880 [emb. PAT. JAN. 5TH 75 REIISD. JUNE 5. 77]	ca. 1879-1880
WHITEMAN / 72 MURRAY S <sup>†</sup> / NEW YORK	unknown	generic	unknown	ca. 1879-1880
WHITEMAN / MAKER / 72 MURRAY S <sup>†</sup> / NEW YORK	THIS BOTTLE TO BE WASHED AND RETURNED NOT TO BE BOUGHT OR SOLD	generic	unknown	1880-1885
none	THIS BOTTLE TO BE WASHED AND RETURNED NOT TO BE BOUGHT OR SOLD	generic	PAT. SEP. 23 84	1884-1890?
WHITEMAN / MAKER / 144 CHAMBERS S <sup>†</sup> / NEW YORK	unknown	Warren Milk Bottle	unknown	1885-1887
WHITEMAN / MAKER / 144 CHAMBERS S <sup>†</sup> / NEW YORK	THIS BOTTLE TO BE WASHED AND RETURNED NOT-TO-BE-BOUGHT-OR-SOLD	Cream Line (Type 1)	PATENTED OCT. 25 1892	1892-ca. 1896
WHITEMAN / M / 144 CHAMBERS ST / 1 / N.Y.*	THIS BOTTLE TO BE RETURNED [also with no embossing]	generic	1883 (not marked on lid)	1887-1891
WHITEMAN / M / 144 CHAMBERS ST / 2 / N.Y.	none	Cream Line (Type 2)	1883 (porcelain covered)	1890-ca. 1896
WHITEMAN / 144 CHAMBERS ST. / N.Y.**	unknown	Cream Line (Types 1 and 3)	unknown	1890-ca. 1896
A.V. WHITEMAN / 144 CHAMBERS ST. / N.Y.	unknown	generic	unknown	1891-ca. 1900
POWELL & LOCKWOOD / MAKERS / 144 CHAMBERS ST. / NEW YORK	THIS BOTTLE TO BE WASHED AND RETURNED	generic	1892 (not marked on lid)	1892-ca. 1895
A.V. WHITEMAN / T. MFG. CO. / 144 CHAMBERS ST. N.Y.	unknown	Cream Line (Type 1)	unknown	ca. 1905

\* Letters include at least B and M; numbers range from at least 1-4.

\*\* This is from Doug Gisi's records and may not be exact.

with A.V. taking over the New York house – perhaps buying out his brothers' shares of that, while L.P. continued to run the factory.

Dating the Whiteman (and Warren) milk bottles and fruit jars is a bit more complex than dating the company. The abrupt shift into milk bottles and away from druggists' ware in 1879 certainly came about in part because of Louis Whiteman's 1880 milk bottle patent. The discovery of lids with *only* the 1875 and 1878 patents for the Lightning finish, coupled with ads for the Warren Milk Bottle as early as July 1879, indicate that the bottle was actually invented by the middle of 1879, even though the patent application was not filed until January 1880.

This explains the beginning of the milk bottle but not the reason for dropping the druggists' jars. The explanation is probably contained in the patent laws. Prior to 1861, patents were assigned for 14 years. That year, the duration of the patent shifted to 17 years and remained that way until the increase to 20 years in 1995. The original Walton patent was issued in 1862 and would have expired in 1879 (Net Industries 2009). Whether the reissue extended the effective period is a question that currently remains unanswered. However, another glass labeling process, invented in 1878, promised to be even more effective. On May 28, 1878, E.L. White received Patent No. 204,272 for a "Method of Labeling Bottles." The new process included "melting the label into the bottle" (Griffenhagen & Bogard 1999:67). The combination of the patent expiration, a new, more effective competitor, and the invention of the milk bottle probably all contributed to the cessation of druggists' jar manufacture by the firm.

The earliest Warren Milk Bottles were only marked "WHITEMAN" on their bases. Other Warren bottles, one subsequent milk jar, and the tin-top jelly jar were all marked with the Murray St. address, probably used from 1879 to ca. 1888. The continuous-thread jelly jar was likely only used during the Cumberland phase of the company, 1880 to 1888, before the plant moved to Uniontown, Pennsylvania.

The Chambers St. address was likely used from 1889 to ca. 1896 – the last ad we have found for the company. However, both generic and Cream Line bottles, embossed "WHITEMAN" at the top (and Chambers St. in the center), were probably only made during the ca. 1889-1891 period, when the Warren plant was still open. Milk bottles with basemarks indicating a manufacture by other glass houses were probably made during the ca. 1891-1896 period. Since Abram Whiteman received a patent in 1900, his operation may have lasted that long. By that time, other milk bottle manufacturers were springing up in competition.

The Whiteman milk bottles with Powell & Lockwood basemarks are also interesting – 112 would be about three blocks away from the 144 Chambers St. address of Whiteman. As noted above, Powell & Lockwood were jobbers – not a glass house. The proximity of the two firms is unlikely to be coincidental, although we have found no direct historical connections between them. Powell & Lockwood was in business by at least 1890 and could not have sold bottles with lids patented in 1892 until at least that year. Since the bottles are at least uncommon (possibly scarce), they cannot have been made for very long. They probably only have a date range of 1892-ca. 1895 or so.

Of course, the Powell & Lockwood connection brings up questions. Was Whiteman beginning to sell off old molds and rights to use them about 1892? What *was* the connection between the two firms? Why did Powell & Lockwood cease production after just a few years? Hopefully, someone in New York City will take up the challenge to find answers locally.

The basemark from the Thatcher Mfg. Co. is equally problematical. The bottle had a distinct Owens machine scar, indicating a manufacture by that method. Thatcher had the exclusive contract for the use of the Owens machine, but the firm did not commence production of bottles by that means until 1905 (Lockhart et al. 2007:56). This indicates that either A.V. Whitman remained in business at least that long or that someone else was using

the Creamline-patented bottle by then. We may never know for sure.

Basemarks suggest that both the generic bottle and the Cream Line bottle were used concurrently during the Chambers St. period. We are currently unable to determine whether the bottles with embossing of the reverse side (the "wash" and/or "return" directives) were used earlier than the ones with no embossing on the reverse or whether those were just choices offered to the dairies.

Future research should include assembling a database of as many of the Warren/Whiteman bottles and closures as possible. The relationship between closure styles, bottle shapes/styles, and basal markings remains a fertile field for study.

## Sources

- Albany Law Journal*  
1886 "Abstracts of Various Recent Decisions."  
*Albany Law Journal* 34(11):218-220.
- American Agriculturist*  
1881 "Bottles for Milk." *American Agriculturist* 40(6):257.
- 1885a Advertisement: "Warren Milk Bottles, Warren Glass Works Co." *American Agriculturist* 44(1):42.
- 1885b Advertisement: "Warren Milk Bottles, A.V. Whiteman." *American Agriculturist* 44(3):134.
- 1887 Advertisement: "Pure Milk." *American Agriculturist* 46(2):87.
- American Druggists' Circular*  
1865a "Advertisement: W.N. Walton." *American Druggists' Circular* 9(2):33.
- 1865b Advertisement: "Walton's Druggists' Glass Works." *American Druggists' Circular* 9(5):93.
- 1866 Advertisement: "Walton's Druggists' Glass Works." *American Druggists' Circular* 10(12):282.
- American Glass Worker*  
1885 "Trade Notes." *American Glass Worker* 1(3):2.
- 1886a "Organized Labor." *American Glass Worker* 1(17):3.
- 1886b "Trade Notes." *American Glass Worker* 1(24):2.



- Brown, Barbara W.  
2008 "[OH-FOOTSTEPS] Oh-Cuyahoga Co. History (Craig Baking Pow)." <http://lists.maggie-sz.org/pipermail/oh-footsteps/2008-December/004557.html>
- Caniff, Tom  
2001 "Fruit Jar Rambles." *American Bottle & Glass Collector* 18(7):32-35.  
  
2008 "Fruit Jar Rambles." *American Bottle & Glass Collector* 25(7):6-9.
- Connellsville Courier, Connellsville, Pennsylvania  
1889 "Glass Notes Gathered Up." *Connellsville Courier*, April 12, 1889:5.  
  
1890a "County Capital." *Connellsville Courier*, January 24, 1890:8.  
  
1890b "The Gas Company Won." *Connellsville Courier*, November 14, 1890:1.  
  
1891a "The Idle Glass Works." *Connellsville Courier*, May 1, 1891:8.  
  
1891b "The Steel Co.'s Affairs." *Connellsville Courier*, May 8, 1891:8.
- Creswick, Alice  
1987 *The Fruit Jar Works, Vol. I, Listing Jars Made Circa 1820 to 1920's*. Douglas M. Leybourne, N. Muskegon, Michigan.
- Crockery Journal*  
1875 Advertisement: "Walton Glass Works." *Crockery Journal* 1(15):1.
- Crockery and Glass Journal*  
1875 "New York." *Crockery and Glass Journal* 2(47):1.  
  
1876a Advertisement: "Walton Glass Works." *Crockery and Glass Journal* 3(26):1.  
  
1876b "The Walton Case." *Crockery and Glass Journal* 4(14):15.  
  
1876c "The Warren Glass Works." *Crockery and Glass Journal* 4(14):15.  
  
1876d Advertisement: "Warren Glass Works." *Crockery and Glass Journal* 4(14):5.  
  
1878 Advertisement: "Warren Glass Works." *Crockery and Glass Journal* 8(26):5.  
  
1879 [Untitled note on L.P. Whiteman milk jar.] *Crockery and Glass Journal* 10(3):16.  
  
1880a [Untitled note on Warren Glass Works.] *Crockery and Glass Journal* 12(10):16.  
  
1880b "Pittsburgh Reports." *Crockery and Glass Journal* 12(14):12.
- 1881 "The Glass Factories." *Crockery and Glass Journal* 14(21):12.  
  
1882 [Untitled note on the Warren Glass Co.] *Crockery and Glass Journal* 16(5):27.  
  
1883a "Glass Factories." *Crockery and Glass Journal* 17(13):14, 16.  
  
1883b "St. Louis Reports." *Crockery and Glass Journal* 17(15):14.  
  
1883c "The Glass Factories." *Crockery and Glass Journal* 17(24):14, 16, 26.  
  
1883d Advertisement: "Warren Glass Works Co." *Crockery and Glass Journal* 18(9):13.  
  
1885 Advertisement: "The Whiteman Fruit Jar." *Crockery and Glass Journal* 21(13):24.  
  
1888a "The Glass Factories: Pittsburgh." *Crockery and Glass Journal* 27(20):21.  
  
1888b "The Glass Factories: Pittsburgh." *Crockery and Glass Journal* 28(4):21.  
  
1888c "The Glass Factories: Pittsburgh." *Crockery and Glass Journal* 28(12):21.  
  
1889 "The Glass Factories: Pittsburgh." *Crockery and Glass Journal* 30(19):21.
- Cultivator & Country Gentleman*  
1880 "Bottled Milk." *Cultivator & Country Gentleman* 45(1452):761.  
  
1890 Advertisement: "Whiteman Milk Jars." *Cultivator & Country Gentleman* 55(1966):775.  
  
1896 Advertisement: "Impure Milk Detected." *Cultivator & Country Gentleman* 61(2247):160.
- Cumberland Glass  
2007 "Cumberland Glass: Warren Glass Works; Queen City Glass Company; Eastern Glass Company." <http://www.cumberlandglass.org/warren.htm>
- Doug & Linda's Dairy Antique Site  
2005-2009 "Bail Top Milk Bottles." Doug & Linda's Dairy Antique Site. [http://dairyantiques.com/Bail\\_Top\\_Milk\\_Bottles.html](http://dairyantiques.com/Bail_Top_Milk_Bottles.html)
- General Assembly of the State of Ohio  
1885 *Executive Documents: Annual Reports for 1884, made to the General Assembly of the State of Ohio at the Adjourned Session, Commencing January 6, 1885*. Westbote Co., State Printers.
- Giarde, Jeffery L.  
1980 *Glass Milk Bottles: Their Makers and Marks*. Time Travelers Press, Bryn Mawr, California.
- Griffenhagen, George and Mary Bogard  
1999 *History of Drug Containers and Their Labels*. American Institute of the History of Pharmacy, Madison, Wisconsin.
- Hagerstown Herald and Torch Light*  
1887 "The February Term." *Hagerstown Herald and Torch Light*, February 10, 1887:3. Hagerstown, Maryland.
- Humphreys, M.S.  
1882 "Glass." *Annual Report of the Pennsylvania Secretary of Internal Affairs*, Vol. 9, Part 3 (Industrial Statistics):56-60.
- Indiana Gazette*  
1890 "Chips from the Keystone." *Indiana Gazette*, December 3, 1890:5. Indiana, Pennsylvania.
- Lockhart, Bill, Pete Schulz, Carol Serr, and Bill Lindsey  
2007 "The Dating Game: Thatcher Glass Mfg. Co." *Bottles and Extras* 18(4):53-65.
- Ladies Home Journal*  
1889 Advertisement: "Whiteman Milk Jars." *Ladies Home Journal* 6(8):14.  
1890 Advertisement: "Whiteman Milk Jars." *Ladies Home Journal* 7(3):23.  
  
1891 Advertisement: "About Milk." *Ladies Home Journal* 64(13):189.
- Net Industries  
2009 "Patents - Patent Duration." Net Industries. <http://law.jrank.org/pages/9086/Patents-Patent-Duration.html>
- New York Board of Fire Underwriters  
1891 *Annual Report of the Committee on Fire Patrol to the New York Board of Fire Underwriters*. N.Y. Economical Printing Co., New York.
- New York Times*  
1885 Glass Blowers on Strike. *New York Times*, July 17, 1885:5.  
  
1900 "Real Estate Transfers: Recorded Leases." *New York Times* August 7:10.  
  
1901 "Rich Man's Strange Death: William E. Whiteman, a Dealer in Milk Bottles, Found Dead in His Rooms." *New York Times* August 6:2.
- Redlands Daily Facts  
1897 *Illustrated Redlands*. Redlands Daily Facts. Adapted for the internet in 2007 by the Redlands Historical Society, Redlands, California. <http://www.illustratedredlands.com/Individuals/CraigW.htm>
- Roller, Dick  
1983 *Standard Fruit Jar Reference*. Acorn Press, Paris, Illinois.

1997 "Uniontown, PA History Notes." Dick Roller files.

*Milkbottles and Related Items*. 2<sup>nd</sup> ed. Privately Printed, Front Royal, Virginia. (1<sup>st</sup> ed. 1989).

Taylor, Gordon A.

1972 *Milk Bottle Manual: A Collector's Pictorial Primer & Pricing Guide*. Old Time Bottle Publishers, Salem, Oregon.

*Tyrone Herald*

1888 [Untitled article on Warren Glass Works.] *Tyrone Herald*, September 18, 1888:1. Tyrone, Pennsylvania.

Thomas Publishing Co.

1905-1906 *The Buyers' Guide: Thomas' Register of American Manufacturers and First Hands in all Lines*. Thomas Publishing Co., New York.

Wilson, Kenneth M.

1972 *New England Glass and Glassmaking*. Old Sturbridge, Inc.

*Youth's Companion*

1891 Advertisement: "It Speaks for Itself." *Youth's Companion* 64(49):634.

1907-1908 *Thomas' Register of American Manufacturers and First Hands in all Lines: The Buyers Guide*. Thomas Publishing Co., New York.

1909 *Thomas' Register of American Manufacturers and First Hands in All Lines: A Classified Reference Book for Buyer and Sellers*. Thomas Publishing, New York.

*Titusville Herald*

1890 "Glass Works Burned." *Titusville Herald*, November 17, 1890:2. Titusville, Pennsylvania.

Tutton, John

1994 *Udderly Delightful: A Guide to Collecting*

[1] The claim that East Stroudsburg was the largest American bottle factory was almost certainly exaggerated. In 1881 at least five Pennsylvania bottle factories had outputs valued more highly (Humphreys 1882:59).

[2] Although the Warren Glass Works Co. website (Cumberland Glass 2007) always added the "Co.," ads for the company called it both the Warren Glass Works, at least until 1878, and the Warren Glass Works Co., by 1880. This seems to reflect a name change corresponding with the 1880 erection of their factory in Maryland.

[3] Cumberland Glass (2007) notes that the factory made "lantern globes, siphons,

battery jars, and other green and amber [sic] containers." The company's ads do indeed include these wares (e.g. *Crockery and Glass Journal* 1883d), but contemporary references to the output of the factory mention nothing but flint glass. It thus seems likely that the New York sales office continued to offer the products of other factories as well as its own. [4] It is interesting that the first page of the patent document (with the drawing) had an incorrect date of May 23, 1867, although the main description included the correct date of May 28, 1867.

[5] Tutton (1994:4) erroneously labeled this Patent No. 3; the actual number was 225,900.

[6] The last ad for the 1884 patent bottles was in 1890; the 1891 ads in the *Ladies Home Journal* did not specify the patent, but by October, 1890, ads in other sources cited the 1888 patent.

[7] Note that the 1885 fruit jar ads (March and June 1885, cite the 1884 patent date. We have discovered no ads citing the 1885 patent date.

[8] The first ad we have for a Whiteman Milk Jar with the 1888 patent date is from October 1890 (*Cultivator & Country Gentleman* 1890). Predictably, the illustration lacks the domed lid of the 1884 patent and has the flat lid of the Carll patent of 1888.

## Searching - can someone help me?

I am searching for battery jars like the damaged ones pictured here.

As you can see, they are part of an art work that got damaged.

They were made for VARTA, a German company and used as marine or telephone batteries. Each was probably a cell unit of a larger battery.

Measurements: H - 9.5", L - 5.5", W - 3".



### Contact:

Claudio Oiticica  
2620 Arrandell Rd  
Midlothian, VA 23113  
Ph: (804) 594-3833

Email: [claudiooiticica@mac.com](mailto:claudiooiticica@mac.com)